

FAZER 500 DOUBLE MITER UPCUT SAW

The FAZER 500 double up miter saw with rising blades is designed for precision miter cuts. With a fixed unit on the left side and a motorized movable unit on the right side. The tilting range is from 90° to 45°. Equipped with double acting vertical clamps, full protection of the saw blades, movable side support of 2.5 m, pneumatic spray mist lubrication and complete with 2 TCT Saw Blades of a 500 mm and 3 kW motors, this unit is fully equipped for your production requirements.



TECHNICAL SPECIFICATIONS:

- Saw blades in TCT Ø500 mm
- Incremental Cutting
- Blade rising with hydro- pneumatic cylinder
- Blade tilting positioning angles from 90° to 45° internal
- Intermediate angles obtained with a mechanical stop
- Maximum cutting length: 4000 mm/ 5000 mm
- Over length cuts are possible with included software
- Minimum cutting length with heads at 90° is 420 mm
- Under minimum cuts are possible with included software
- Spray mist blade lubrication system
- Blade tilting and rising on precision bearings
- Mobile carriage movement by Digital Brushless Motor

EQUIPPED WITH ELECTRONIC POSITIONER:

- N.2 Vertical and N.1 horizontal clamps per head
- Cutting area completely protected
- Pneumatically actuated guards
- Pneumatic mist spray
- Movable roller side support
- Air gun
- Windows 10 TouchScreen CNC control
- Cutting list capabilities
- TCT Saw blade Ø500 mm

FAZER 500 DOUBLE MITER UPCUT SAW

OPTIONS:

- Dust extractor
- Intermediate pneumatic support
- Microdrop lubrication with pure oil
- Label printer
- 5 meters cutting length
- Extra clamp

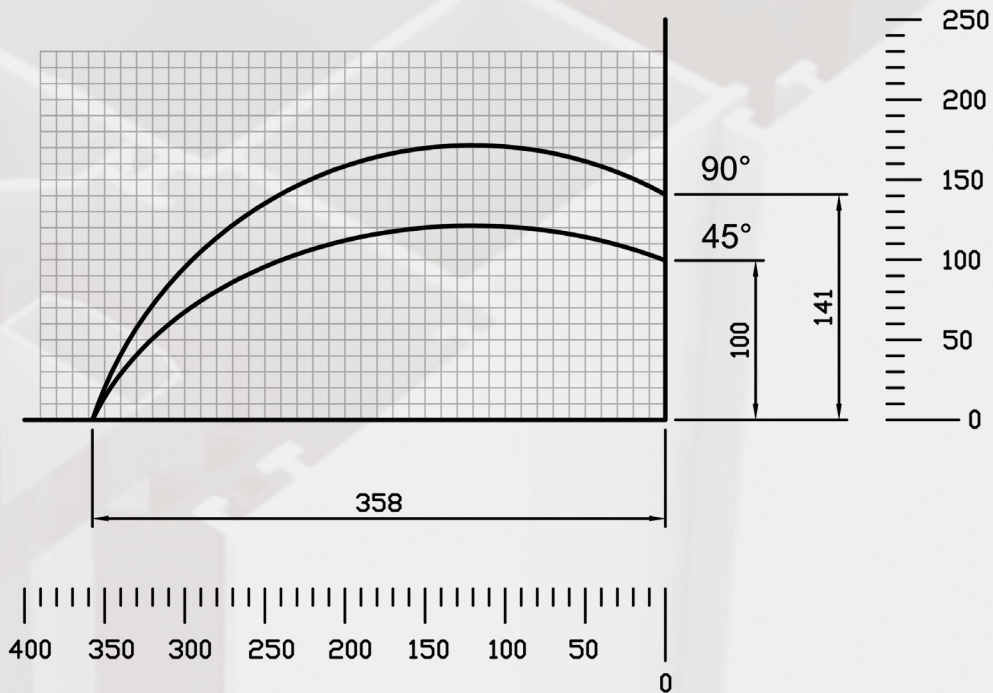
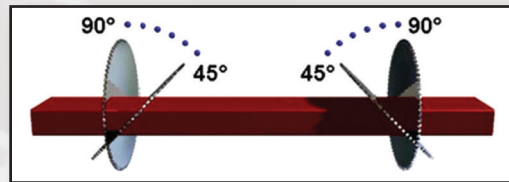
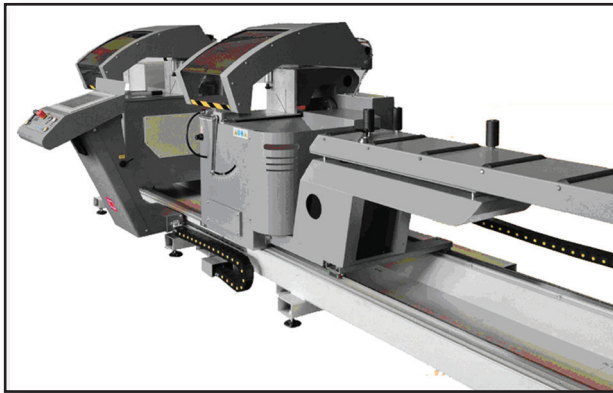

| Ingombro Overall dimensions - Abmessungen - Dimensiones - Dimensões - Encombrement | | | | Peso Weight - Gewicht - Poids | |
|---|------|------|------|----------------------------------|--|
| | L | W | H | | |
| 4000 | 1930 | 5920 | 1450 | Kg. 1620 | |
| 5000 | 1930 | 6920 | 1450 | Kg. 1750 | |